

CGHN-S : Single-ended blades, used for grooving and turning.

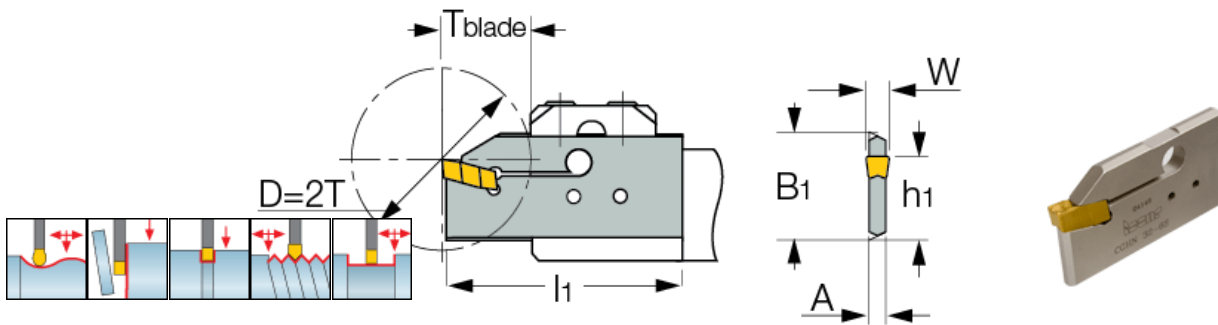

Designation	B1	W min	W max	T blmin	T blade	h1	l1	A
CGHN 32-3S	32	2.8	4	10	19	24.8	51	2.4
CGHN 32-4S	32	3.5	5	12	21	24.8	53	3.2
CGHN 32-5S	32	4.4	6.4	12	25	24.8	56	4
CGHN 32-6S	32	5.5	6.4	12	25	24.8	56	5.2

When using a double-ended insert, grooving depth is limited by the insert.