

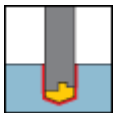

**DR-3XD-CF (17 & 22 mm 3xD)** : Indexable drills with a CLICKFIT adaptation, using square inserts. Drilling depth 3xD.

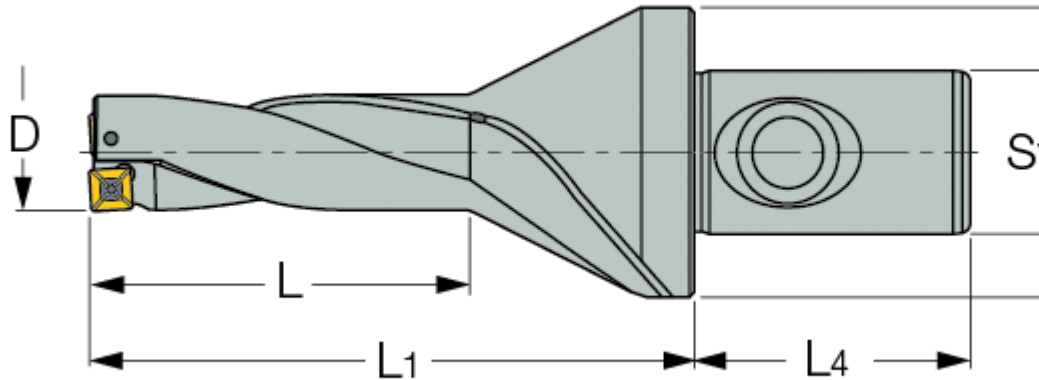

Designation	D	L	L1	D max	L4	Style/d	D3
DR017-051-CF4-06	17.00	51.0	82.0	20.00	42.0	CF4	44.00
DR022-066-CF4-06	22.00	66.0	101.0	23.00	42.0	CF4	44.00

Hole diameter can be changed by shifting drill center along lathe X-axis.

Hole tolerance:  $D+0.10/-0.05$  in average conditions. However, it can be higher or lower according to machine and tooling conditions.

For Adaptation Click on "More Info"