

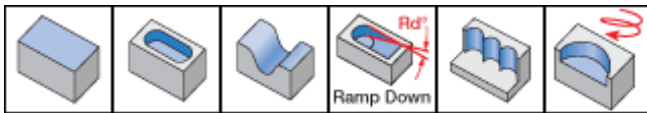

FF FW : FEEDMILL, fast feed face mills using FF WOMT... inserts. Can run at very high feed rates of up to 3.5 mm/t at small DOC, re

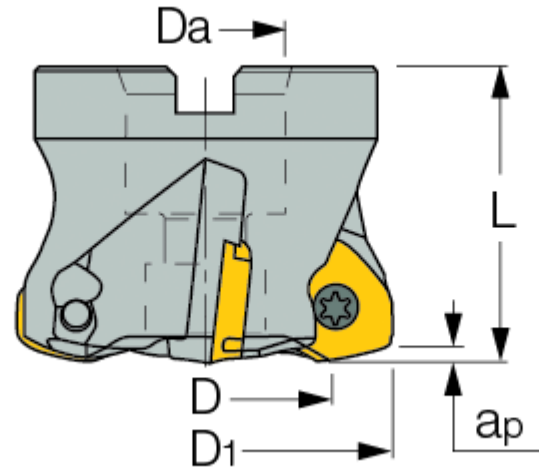

Designation	D1	D	Z	L	ap	Da	Rd?/b>	Arbor	Nxcm	Kg
FF FW D40-16-06-C	40.0	26.00	4	35.00	1.50	16.00	2.5	A	200	0.30
FF FW D50-22-06-C	50.0	36.00	5	40.00	1.50	22.00	2.0	A	200	0.45
FF FW D52-22-06-C	52.0	38.00	5	40.00	1.50	22.00	1.9	A	200	0.48
FF FW D50-22.225-09-C	50.0	29.20	4	50.00	2.00	22.22	2.0	A	500	0.51
FF FW D50-22.225-09-CP	50.0	29.20	3	50.00	2.00	22.22	4.0	A	500	0.50
FF FW D50-22-09-C	50.0	29.20	4	50.00	2.00	22.00	4.0	A	500	0.30
FF FW D50-22-09-CP	50.0	29.20	3	50.00	2.00	22.00	4.0	A	500	0.50
FF FW D52-22-09-C	52.0	31.20	4	40.00	2.00	22.00	4.0	A	500	0.54
FF FW D52-22-09-CP	52.0	31.20	3	40.00	2.00	22.00	4.0	A	500	0.44
FF FW D63-22.225-09-C	63.0	42.20	5	50.00	2.00	22.22	3.0	A	500	0.78
FF FW D63-22.225-09-CP	63.0	42.20	4	50.00	2.00	22.22	3.0	A	500	0.77
FF FW D63-22-09-C	63.0	42.20	5	40.00	2.00	22.00	3.0	A	500	0.47
FF FW D63-22-09-CP	63.0	42.20	4	40.00	2.00	22.00	3.0	A	500	0.66
FF FW D63-27-09-C	63.0	42.20	5	50.00	2.00	27.00	3.0	A	500	0.76
FF FW D66-22-09-C	66.0	45.20	5	40.00	2.00	22.00	2.8	A	500	0.60
FF FW D66-27-09-C	66.0	45.20	5	50.00	2.00	27.00	2.8	A	500	0.82
FF FW D80-31.75-09-C	80.0	59.20	5	60.00	2.00	31.75	0.5	A	500	1.73
FF FW D80-32-09-C	80.0	59.20	5	50.00	2.00	32.00	2.0	A	500	0.96
FF FW D100-31.75-09-C	100.0	79.20	6	63.00	2.00	31.75	2.0	B	500	2.24
FF FW D100-32-09-C	100.0	79.20	6	50.00	2.00	32.00	1.5	B	500	1.59
FF FW D125-38.1-09-C	125.0	104.20	7	63.00	2.00	38.10	1.0	B	500	3.16
FF FW D125-40-09-C	125.0	104.20	7	63.00	2.00	40.00	1.0	B	500	2.80

The CP (Coarse Pitch) tools were designed to run 2.5 mm/tooth at 2 mm DOC, while the regular pitch cutter run at 3.5 mm/tooth at 1 mm DOC.

