

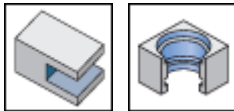

GM : Endmills for groove milling, carrying GIPI/GIFI/TIPI inserts (CUT-GRIP).

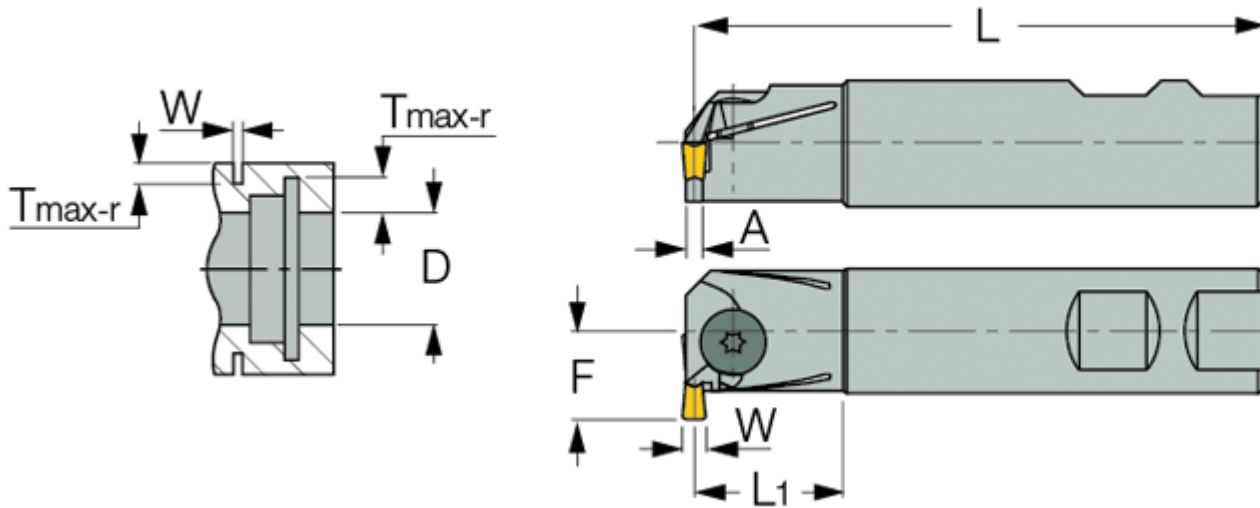

Designation	W max	d	D min	Tmax	L	L1	F	A	Shank
GM 30-W20	4.00	20.00	30.00	4.60	90.00	20.0	30.0	2.40	W
GM 35-W25	6.40	25.00	35.00	5.00	100.00	25.0	35.0	3.50	W

For adaptation, click on "More Info".

For W