

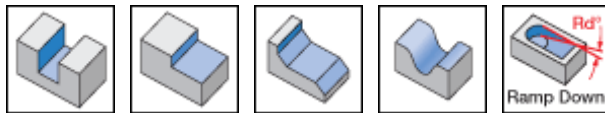

**ERCM** : CHAMMILL, Multifunctional coarse-pitch endmills. Can carry four different insert shapes.

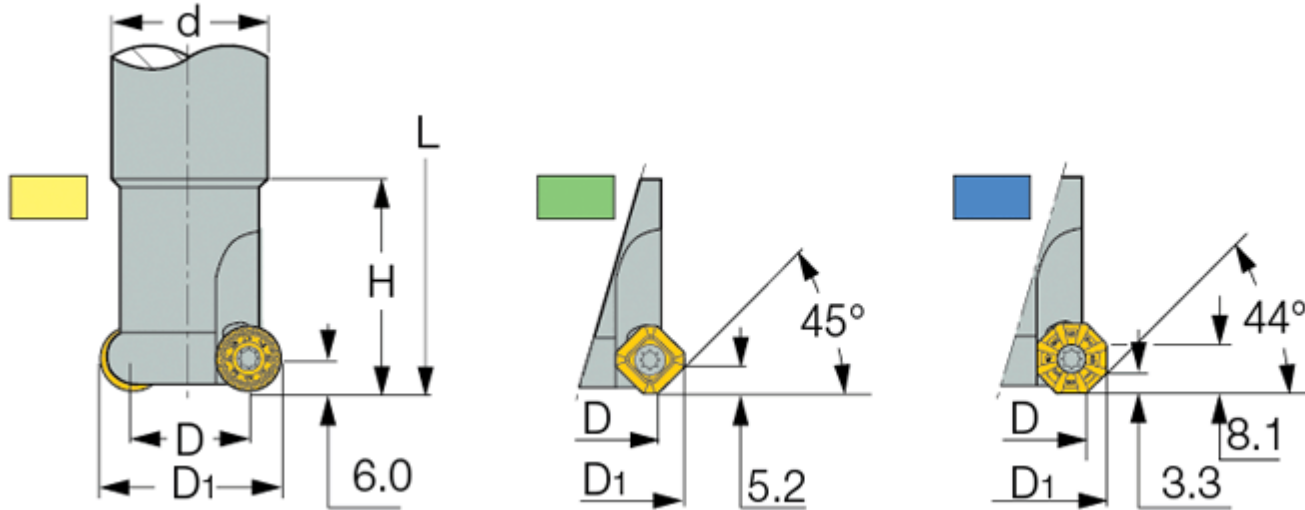

Designation	D1	D	Z	H	Rd°	ap	L	d	Shank	Kg
ERCM D32-C25-CP12	32.0	20.00	2	40.00	10.0	6.00	180.00	25.00	C	0.79
ERCM D32-C32-CP12	32.0	20.00	2	40.00	10.0	6.00	230.00	32.00	C	1.39
ERCM D40-C32-CP12	40.0	28.00	3	40.00	6.5	6.00	200.00	32.00	C	1.34

For adaptation click on "More Info".

The displayed data refers to R90MT inserts, for other combinations see "More Info".