

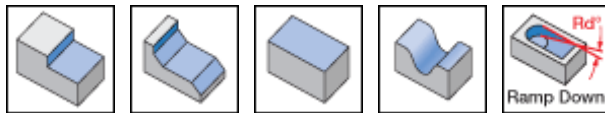

FRCM : CHAMMILL, coarse pitch multi-functional face mills for four different insert contours.

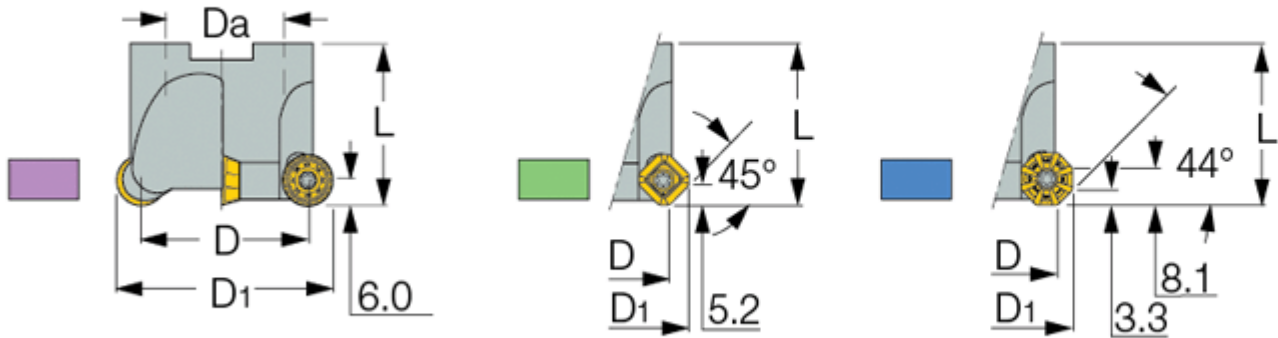

Designation	D	D1	Z	L	Rd°	ap	Da	Arbor	Kg
FRCM D50-22-CP12	38.00	50.0	4	40.00	4.3	6.00	22.00	A	0.25
FRCM D52-22-CP12	50.00	52.0	5	40.00	4.3	6.00	22.00	A	0.25
FRCM D63-22-CP12	51.00	63.0	5	40.00	3.2	6.00	22.00	A	0.44
FRCM D66-27-CP12	54.00	66.0	6	50.00	3.2	6.00	27.00	A	0.54
FRCM D80-27-CP12	68.00	80.0	6	50.00	2.5	6.00	27.00	B	0.83

The displayed data refers to R90MT inserts, for other combinations see "More Info".