

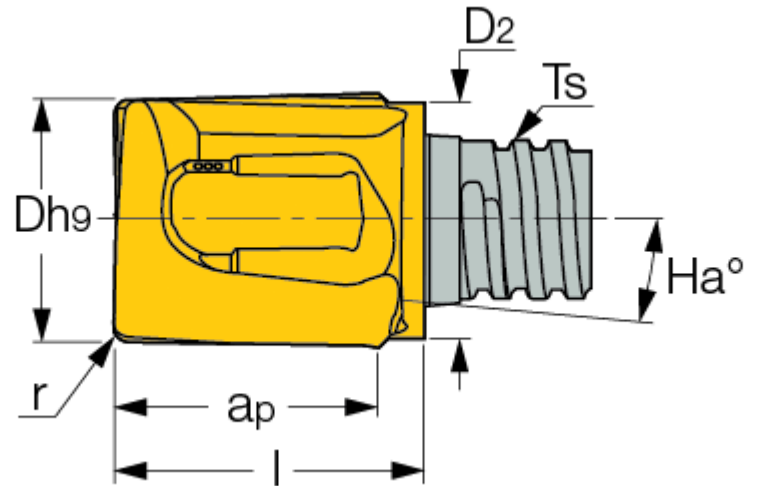

MM HC : MULTI-MASTER, interchangeable, solid carbide slot drill milling heads with two 10° helix flutes. Available with a variety of c



Economical solution



Designation	D	Flute	ap	r	Ts	D2	l	Ha°	Tm	Nxcm	fz(min)	fz(max)	Grade
MM HC078C08R0.2-2T05	7.80	2	8.00	0.20	T05	7.60	10.00	10.0	r0-2.0	700	0.03	0.09	IC908
MM HC080C08R0.4-2T05	8.00	2	8.00	0.40	T05	7.60	10.20	10.0	r0-2.0	700	0.03	0.09	IC908 IC903
MM HC080C08R1.0-2T05	8.00	2	8.00	1.00	T05	7.60	10.20	10.0	r0-2.0	700	0.03	0.09	IC908 IC903
MM HC080C08R2.0-2T05	8.00	2	8.00	2.00	T05	7.60	10.20	10.0	r0-2.0	700	0.03	0.09	IC908 IC903
MM HC098C10R0.3-2T06	9.80	2	9.00	0.30	T06	9.60	12.40	10.0	r0-3.0	700	0.03	0.10	IC908
MM HC100C10R0.4-2T06	10.00	2	9.00	0.40	T06	9.60	12.40	10.0	r0-3.0	1000	0.03	0.10	IC908 IC903
MM HC100C10R1.0-2T06	10.00	2	9.00	1.00	T06	9.60	12.40	10.0	r0-3.0	1000	0.03	0.10	IC908 IC903
MM HC100C10R2.0-2T06	10.00	2	9.00	2.00	T06	9.60	12.40	10.0	r0-3.0	1000	0.03	0.10	IC908 IC903
MM HC117C13R0.3-2T08	11.70	2	10.00	0.30	T08	11.50	14.20	10.0	r0-3.0	1500	0.04	0.11	IC908
MM HC120C13R0.4-2T08	12.00	2	10.00	0.40	T08	11.50	14.20	10.0	r0-3.0	1500	0.04	0.11	IC908 IC903
MM HC120C13R1.0-2T08	12.00	2	10.00	1.00	T08	11.50	14.20	10.0	r0-3.0	1500	0.04	0.11	IC908 IC903
MM HC120C13R2.0-2T08	12.00	2	10.00	2.00	T08	11.50	14.20	10.0	r0-3.0	1500	0.04	0.11	IC908 IC903
MM HC.500C55R016-2T08	12.70	2	11.00	0.40	T08	11.50	15.20	10.0	r0-3.2	1500	0.04	0.11	IC908
MM HC140C11R0.4-2T08	14.00	2	11.90	0.40	T08	11.50	15.05	10.0	r0-4.0	1500	0.04	0.12	IC908
MM HC157C16R0.3-2T10	15.70	2	15.00	0.30	T10	15.20	19.00	10.0	r0-4.0	2800	0.05	0.13	IC908
MM HC160C16R0.4-2T10	16.00	2	15.00	0.40	T10	15.20	19.00	10.0	r0-4.0	2800	0.05	0.13	IC908 IC903
MM HC160C16R0.8-2T10	16.00	2	15.00	0.80	T10	15.20	19.00	10.0	r0-4.0	2800	0.05	0.13	IC908 IC903

For Clamping keys (should be ordered separately), tightening torques and clamping instructions, click on "More Info".

Do not apply lubricant to the threaded connection.

