

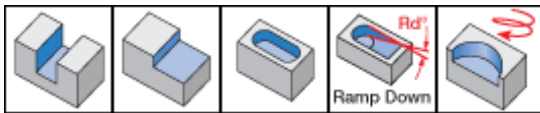

HM90 EAL-HSK63A-15 : Long reach endmills with integral HSK adaptation, used for machining aluminum, carrying HM90 AXCR 15

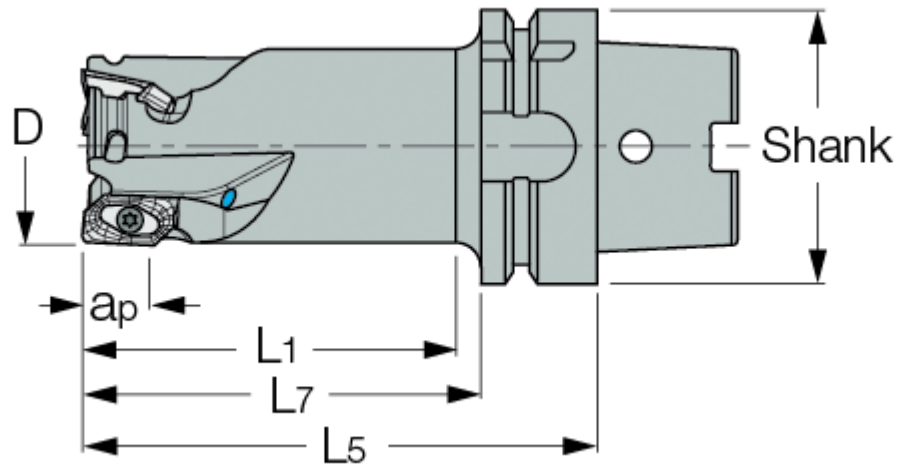

| Designation | D | L1 | Z | ap | L7 | L5 | RPM max | Rd?/b> | Shank | Kg |
|---------------------------|-------|-------|---|-------|--------|--------|---------|--------|----------|------|
| HM90 EAL25-L50-HSK63A-15 | 25.00 | 45.0 | 2 | 15.00 | 50.00 | 76.00 | 37500 | 21.0 | HSK A 63 | 0.87 |
| HM90 EAL25-L75-HSK63A-15 | 25.00 | 70.0 | 2 | 15.00 | 75.00 | 101.00 | 31250 | 21.0 | HSK A 63 | 0.82 |
| HM90 EAL32-L65-HSK63A-15 | 32.00 | 60.0 | 3 | 15.00 | 65.00 | 91.00 | 31250 | 13.0 | HSK A 63 | 1.02 |
| HM90 EAL32-L100-HSK63A-15 | 32.00 | 95.0 | 3 | 15.00 | 100.00 | 126.00 | 31250 | 13.0 | HSK A 63 | 1.21 |
| HM90 EAL40-L80-HSK63A-15 | 40.00 | 75.0 | 3 | 15.00 | 80.00 | 106.00 | 26040 | 9.0 | HSK A 63 | 1.31 |
| HM90 EAL40-L120-HSK63A-15 | 40.00 | 115.0 | 3 | 15.00 | 120.00 | 146.00 | 26040 | 9.0 | HSK A 63 | 1.66 |

A cooling tube must be used with all internal coolant HSK spindles (should be ordered separately)

Insert tightening torque: 350 Nxcm

Balanced to G2.5/max RPM