

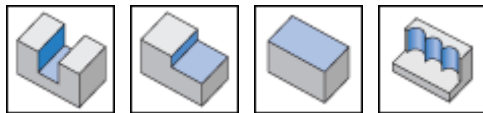

H490 E90AX-MM : 90° endmills with MULTI-MASTER threaded connection, using H490 ANKX/ANCX 09 double-sided rectangular ins

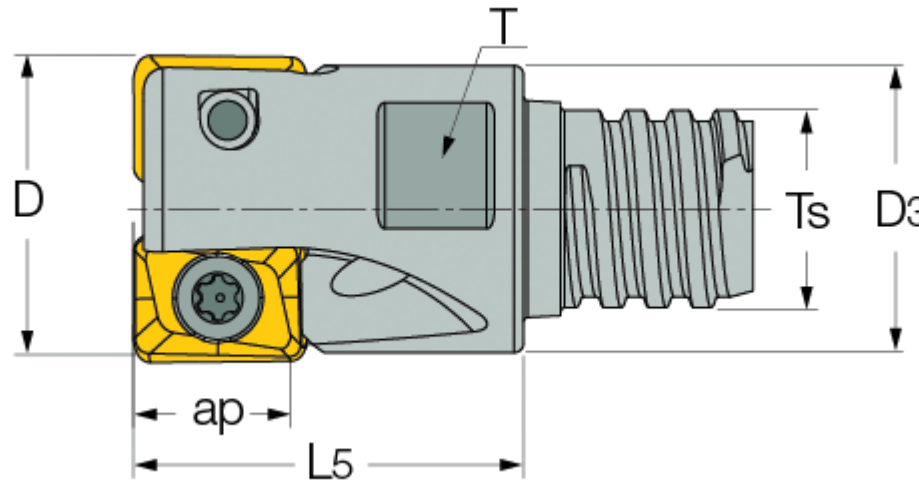

Designation	D	Z	ap	L5	D3	Ts	T	
H490 E90AX D16-2-MMT10-09	16.00	2	8.00	23.00	15.30	T10	13.0	-
H490 E90AX D20-3-MMT12-09	20.00	3	8.00	24.00	19.30	T12	16.0	-

For adaptation, click on "More Info".