

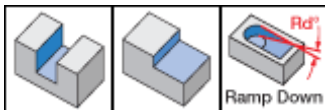

ADK : Extended flute cutters with HELIMILL ADKT/R-15.. inserts

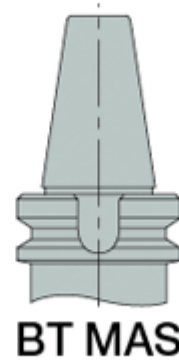
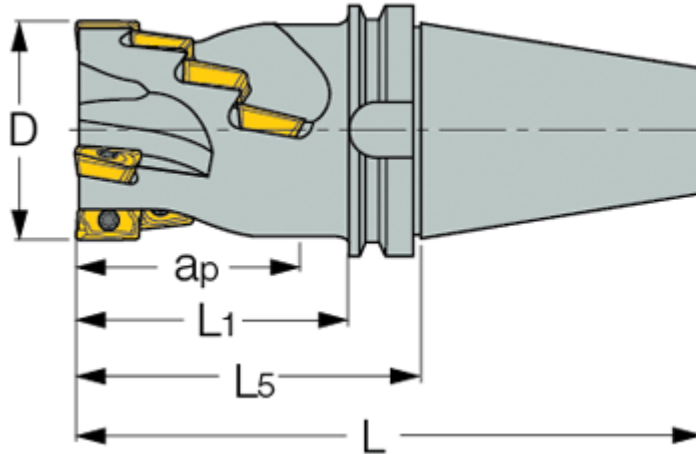

Designation	D	Z	Flute	ap	L	L1	L5	d	Shank	Rd?/b>	Kg
ADK D 32- 25-W32	32.00	4	2	25.00	108.00	48.0	-	32.00	W	2.5	0.53
ADK D 40- 38-W32	40.00	6	2	38.00	115.00	50.0	-	32.00	W	2.0	0.66
ADK D 45- 50-W32	45.00	8	2	51.00	122.00	62.0	-	32.00	W	0.0	0.72
ADK D 50- 50-W42-FP	50.00	10	3	51.00	140.00	63.0	-	42.00	W	0.9	1.34
ADK D 50- 50-W32	50.00	12	3	51.00	122.00	52.7	-	32.00	W	0.9	0.86
ADK D 50- 50-W40	50.00	12	3	51.00	135.00	55.0	-	40.00	W	0.9	1.20
ADK D 50-100.....JPN	50.00	16	2	101.60	205.00	115.0	-	42.00	W	0.9	2.07
ADK D 50-100-W40	50.00	16	2	101.00	192.00	110.0	-	40.00	W	0.9	1.62
ADK D50-100-BT50	50.00	16	2	101.00	265.00	128.0	164.00	-	BT50	0.9	4.68
ADK D63-63-BT50	63.00	18	3	64.00	237.00	100.0	135.00	-	BT50	0.6	5.30
ADK D63-63-INT50	63.00	18	3	64.00	222.00	100.0	120.00	-	INT50	0.6	4.39
ADK D80-85-BT50	80.00	24	3	89.00	254.00	117.0	152.00	-	BT50	0.5	6.94
ADK D80-85-INT50	80.00	24	3	89.00	235.00	113.0	133.00	-	INT50	0.5	5.80

The INT suffix stands for DIN69871 shank standard
For adaptation, click on "More Info".