

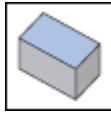

3M E45AX-20 : MILL2000, Heavy duty 45° endmills using 3M AXKT 2006... inserts with dovetail section shape, helical cutting edges applications.

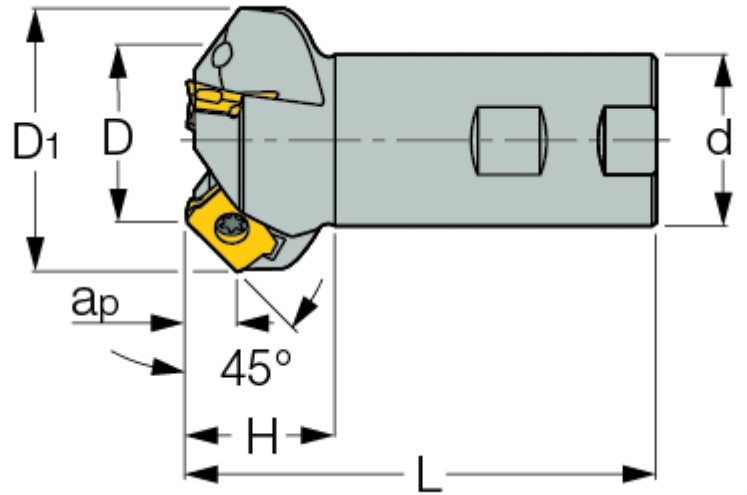

Designation	D	D1	ap	Z	H	L	d	Shank	Kg
3M E45AX D40-3-W40-20	40.00	62.0	10.00	3	35.00	110.00	40.00	W	1.08

For adaptation, click on "More Info".