

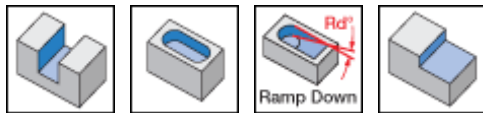

**HM90 EAL-CF4-16** : Long reach endmills with CLICKFIT Adaptation for machining aluminum, carrying HM90 APCR 1605... inserts (H

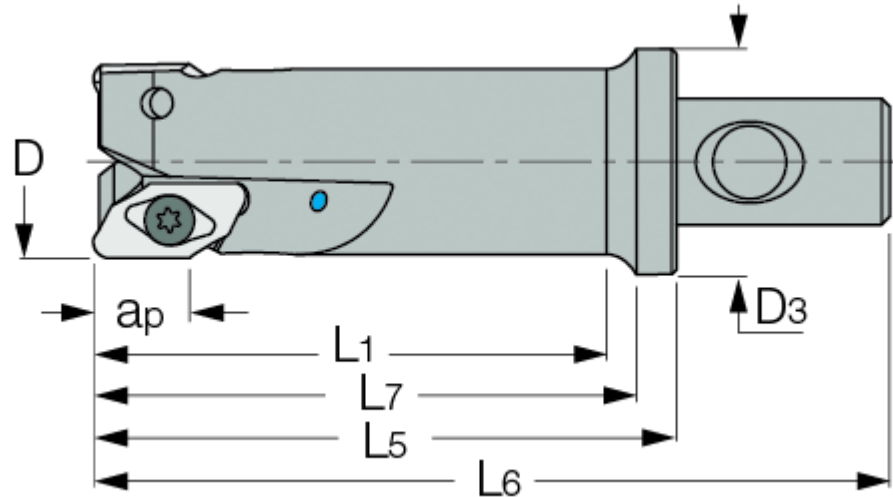

Designation	D	Z	ap	L1	L7	L5	L6	Shank	D3	RPM max	Rd°	Kg
HM90 EAL-D25-L90-CF4-16	25.00	1	15.80	87.0	90.50	98.50	140.50	CF4	44.00	7000	25.9	0.80
HM90 EAL-D32-L90-CF4-16	32.00	2	15.80	87.0	90.50	98.50	140.50	CF4	44.00	7000	22.4	0.50
HM90 EAL-D40-L90-CF4-16	40.00	2	15.80	87.0	90.50	98.50	140.50	CF4	44.00	7000	16.9	1.00

D.O.C. changes according to insert radius

Insert tightening torque: 600 Nxcm

HM90 APCR 1605..R-P inserts with corner radii larger than 4.5 mm should be used only on BR tools

For adaptation click on "More Info"