

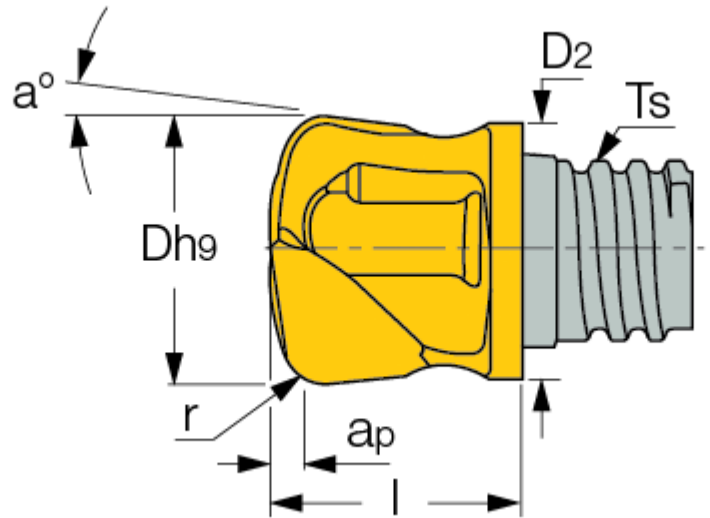

**MM FF** : MULTI-MASTER, 2 flute, FEEDMILL, interchangeable solid carbide heads. Used for milling at very high feed and small D.O.C.



Economical solution



Designation	D	Z	ap	r	Ts	D2	l	a°	Rd°	fz(min)	fz(max)	Grade
MM FF100R1.5-L12-2T06	10.00	2	0.60	2.00	T06	9.60	12.50	10	90.0	0.30	0.60	IC908
MM FF120R2.0-2T08	12.00	2	1.00	2.50	T08	11.50	11.10	10	90.0	0.50	1.00	IC908 IC903
MM FF500R08-L59-2T08	12.70	2	1.00	2.00	T08	11.50	15.00	10	90.0	0.50	1.00	IC908
MM FF160R2.0-L20-2T10	16.00	2	1.10	3.00	T10	15.20	20.00	10	90.0	0.55	1.10	IC908
MM FF160R2.0-2T10	16.00	2	1.10	3.00	T10	15.20	13.50	10	90.0	0.55	1.10	IC908
MM FF200R2.0-2T12	20.00	2	1.50	3.30	T12	18.30	17.50	10	90.0	0.75	1.50	IC908

For clamping keys (should be ordered separately), tightening torques and clamping instructions, click on "More Info".

Do not apply lubricant to the threaded connection.