

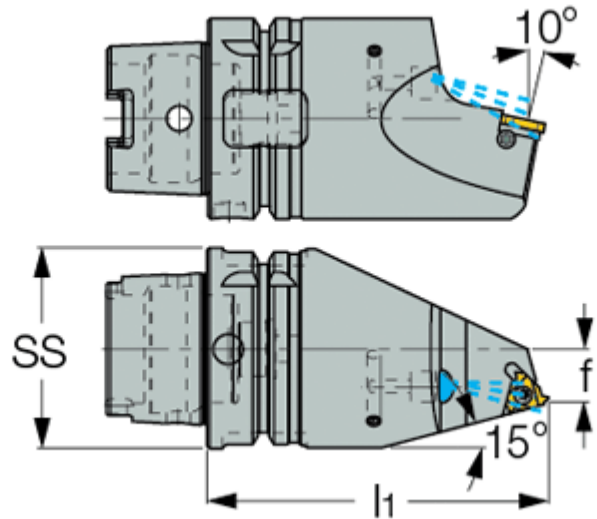

HSK A63WH-SEL : External threading tools with HSK exchangeable shanks for 15° mounting on turn-mill machines.

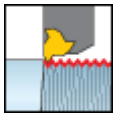

Complies with the ICTM and HSK-T standards.
Left-hand shown



Designation	SS	l1	f	R/L
HSK A63WH-SEL-J16	63	110.00	17.0	L

A cooling tube must be used with all coolant through HSK spindles (should be ordered separately).

For shank dimensions, see more info.