

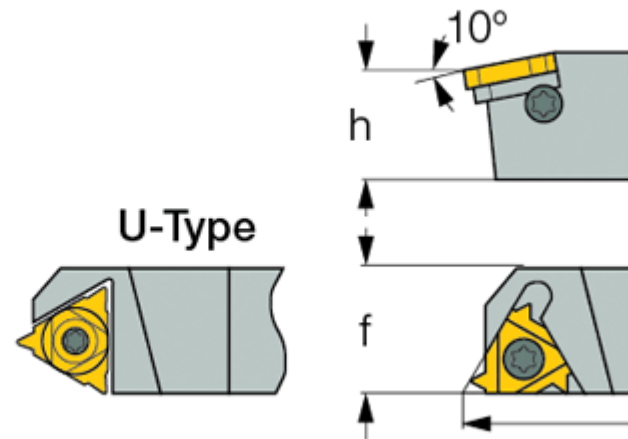

SER/L : External threading toolholders (AD - short tools for adapter holders).

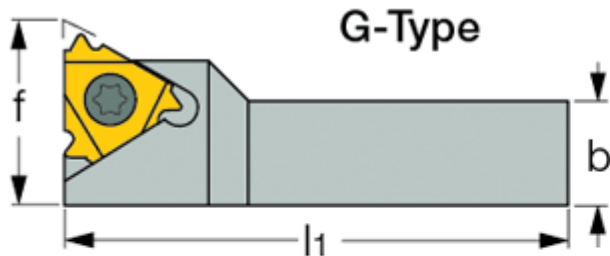

Right-hand shown

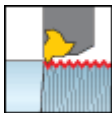

Designation	h	b	l1	f
SER 0808 H11	8.0	8.0	100.00	11.0
SEL 1010 H11	10.0	10.0	100.00	11.0
SER 1010 H11	10.0	10.0	100.00	11.0
SEL 1212 F16	12.0	12.0	80.00	16.0
SER 1212 F16	12.0	12.0	80.00	16.0
SEL 1616 H16	16.0	16.0	100.00	16.0
SER 1616 H16	16.0	16.0	100.00	16.0
SER 1616 K16G	16.0	16.0	125.00	21.7
SEL 2020 K16	20.0	20.0	125.00	20.0
SEL 2020-16-AD	20.0	20.0	67.00	25.0
SER 2020 K16	20.0	20.0	125.00	20.0
SER 2020-16-AD	20.0	20.0	67.00	25.0
SEL 2525 M16	25.0	25.0	150.00	25.0
SER 2525 M16	25.0	25.0	150.00	25.0
SEL 3232 P16	32.0	32.0	170.00	32.0
SER 3232 P16	32.0	32.0	170.00	32.0
SEL 2525 M22	25.0	25.0	150.00	25.0
SEL 2525 M22U	25.0	25.0	150.00	28.0
SER 2525 M22	25.0	25.0	150.00	25.0
SER 2525 M22U	25.0	25.0	150.00	28.0
SEL 3232 P22	32.0	32.0	170.00	32.0
SER 3232 P22U	32.0	32.0	170.00	32.0
SER 3232 P22	32.0	32.0	170.00	32.0
SER 3232 P22U	32.0	32.0	170.00	32.0
SEL 4040 R22	40.0	40.0	200.00	40.0
SEL 4040 R22U	40.0	40.0	200.00	40.0
SER 4040 R22	40.0	40.0	200.00	40.0

SEL 2525 M27	25.0	25.0	150.00	25.0
SEL 2525 M27U	25.0	25.0	150.00	32.0
SER 2525 M27	25.0	25.0	150.00	25.0
SEL 3232 P27	32.0	32.0	170.00	32.0
SEL 3232 P27U	32.0	32.0	170.00	32.0
SER 3232 P27	32.0	32.0	170.00	32.0
SER 3232 P27U	32.0	32.0	170.00	32.0
SEL 4040 R27U	40.0	40.0	200.00	40.0
SER 4040 R27	40.0	40.0	200.00	40.0

All toolholders are made for 1.5 helix angle.
For GTGA inserts, use anvil AE 16-0