

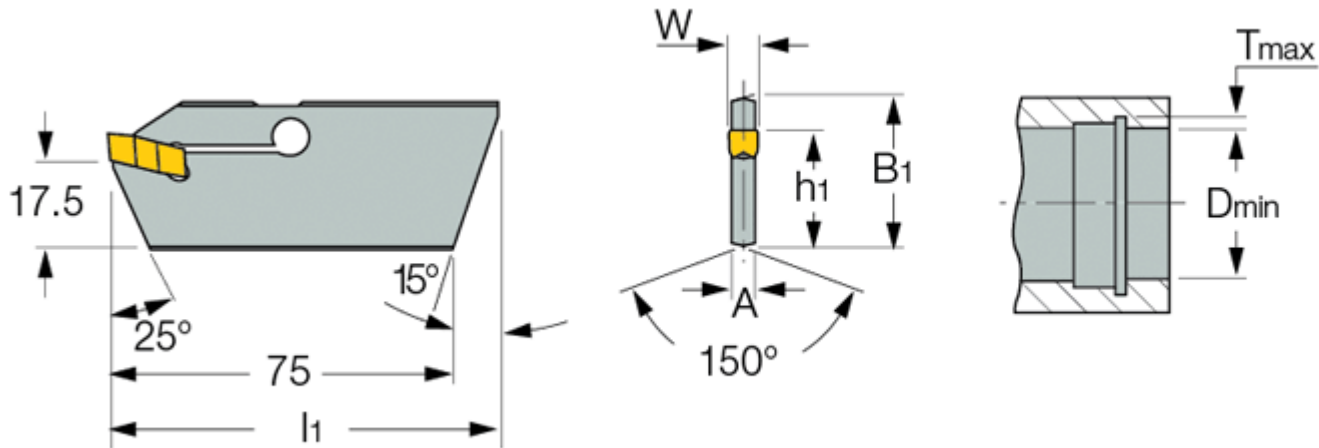

**CGHN 32-M** : Internal grooving and turning blades.

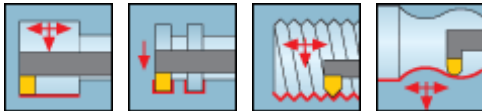

CGHN 32-...M blade can be modified from external blades CGHN 32-...D



Designation	W min	W max	A	fmin	F1min	fmax	F1max	h1	l1	B1	D min
CGHN 32-3M	2.80	4.00	2.40	44.0	15.0	48.0	19.0	24.8	82.00	32.0	85.00
CGHN 32-4M	3.60	5.00	3.20	44.0	15.0	50.0	21.0	24.8	82.00	32.0	85.00
CGHN 32-5M	4.40	6.40	4.00	44.0	15.0	55.0	26.0	24.8	82.00	32.0	85.00
CGHN 32-6M	5.60	6.40	5.20	44.0	15.0	55.0	26.0	24.8	82.00	32.0	85.00

f and F1 are the blade extension range.

Grooving depth (Tmax-r) varies in conformance with blade's overhang (F1) and it depends on the bore diameter (D). For grooving capacity, click "More Info"